

BRUCHA panel FP-P

facade PREMIUM concealed fastened

PIR+
nonhalogen

iQTec
foam technology®

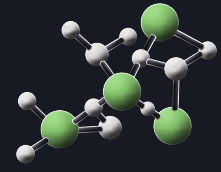

exterior PROFILE options - close-up

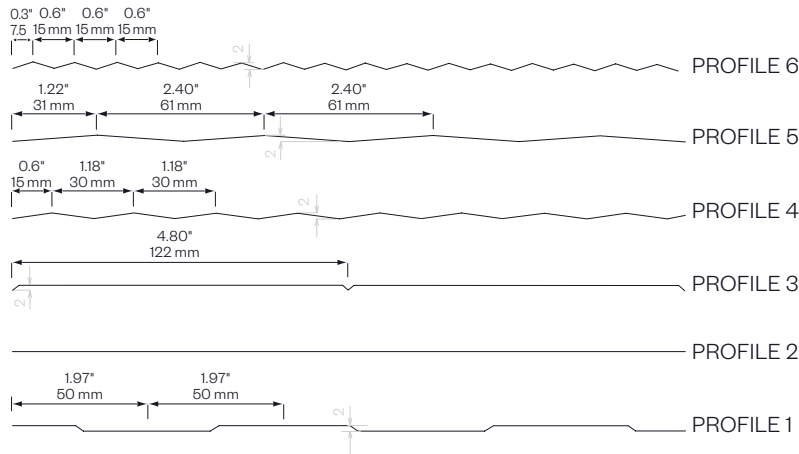

symbol image - FP-P profile 6

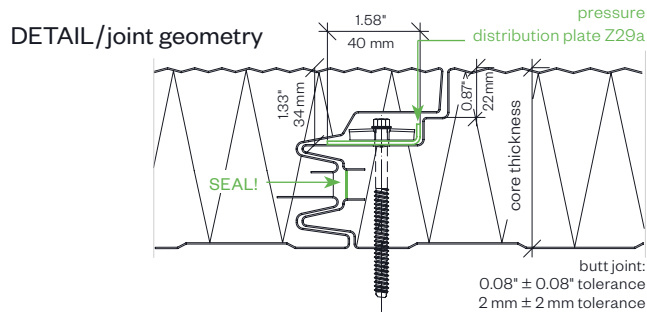

PANEL TYPE	FP-P 80	FP-P 100	FP-P 120	FP-P 140	FP-P 160	FP-P 180	FP-P 200
core thickness in ≈ inch	3"	4"	4.5"	5.5"	6.5"	7"	8"
in mm	80	100	120	140	160	180	200
PIR+ non-halogen, R-value thermal performance at 75°F	25	31	37	43	49	55	61
iQTec on request, R-value thermal performance at 75°F	26.5	33	39	45	52	58	64
weight in lb/ft ²	2.41	2.57	2.73	2.90	3.60	3.23	3.39
in kg/m ²	11.75	12.55	13.35	14.15	14.95	15.75	16.55

MANUFACTURING LENGTHS

39' 2" or 11.95 m (44' 3 1/2" or 13.50 m)

R-VALUE

~7.50 per inch @75°F mean temperature
~8.25 per inch @35°F mean temperature

SPAN WIDTH TABLES

according static tables

PERMANENT TEMPERATURE RESISTANCE

176°F/80°C

BRUCHA®

PIR+
nonhalogen

iQTec
foam technology®

BRUCHA panel FP-P

facade PREMIUM concealed fastened

DESIGN AND SURFACES Standard - coil-coated, hot-dip galvanised steel sheet

EXTERIOR

- Exposed side 25 µm polyester coating with a PVC protective film (not UV-resistant - protect from direct sunlight).
The film must be removed before installation or immediately afterwards.
- profile 6 = Standard, for other profiles see FP-P PROFILE options
- metal gauge: 24 ga / 0.6 mm (smaller metal gauge on request)

INTERIOR

- Exposed side 25 µm polyester coating with a PVC protective film (not UV-resistant - protect from direct sunlight).
The film must be removed before installation or immediately afterwards.
- profile 1 = standard (profile 2 and 3 on request)
- metal gauge: 26 ga / 0.5 mm (smaller metal gauge on request)

INSULATION CORE

- nonhalogen** PIR/polyurethane rigid foam, approx. 96 % closed cells, continuously foamed
- absolutely no chlorofluorocarbons or halogenated chlorofluorocarbons – pentane foam process
- low thermal conductivity
- securely attached to the steel sheet
- density approx. 2.50 lb/ft³ or 40 kg/m³

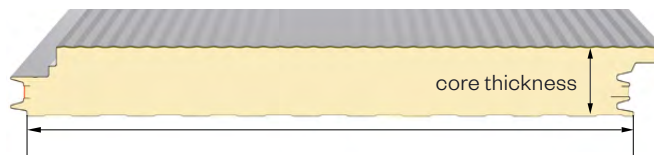

construction width 39 3/8" or 1000 mm (35 3/8" or 900 mm special width on request)

STANDARD COLORS

in accordance with BASIC color range

PANEL CONNECTION

Double tongue and groove system in which the special labyrinth profile allows the screw head to be countersunk and fully covered by the next panel – **covered, concealed fastened**. The integrated seals guarantee maximum wind proofing. The panels interlink precisely with no thermal bridge. The PREMIUM FP-P facade panel offers outstanding structural characteristics, as well as enabling even greater span widths through the use of the pressure distribution plate.

TENDER TEXT

download from: bruchacom

EXTERNAL MONITORING

National and international tests and quality standards. We will send the certificates on request.

Contact:

BRUCHA Corp.
4949 S Syracuse Street, Suite 550
Denver, CO 80237

T: 866.BRUCHA1
M: infousa@bruchacom
bruchacom



bruchacom

